

# M-PC2 Connectivity

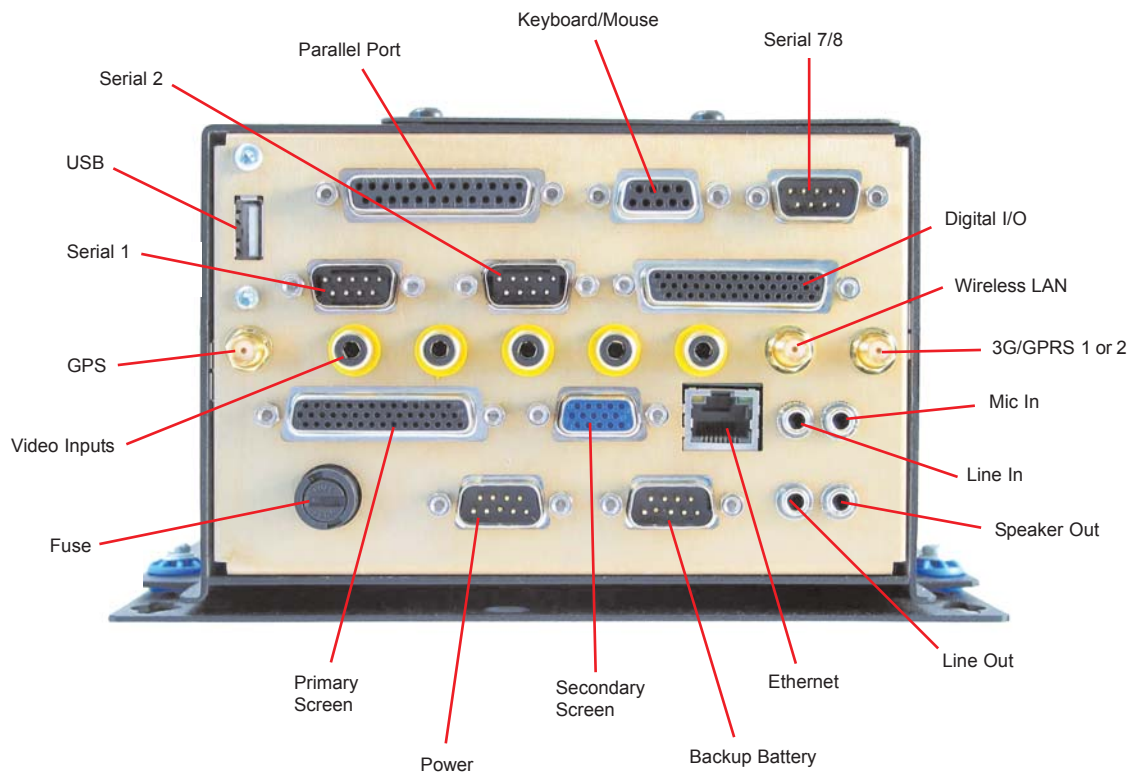

The Microbus M-PC2 Vehicle PC driven by Windows® XP/2000 offers a wide range of interfaces to meet the demands of vehicle mobile applications. With more connectivity than is usually provided in laptop, tablet or desktop devices, the Vehicle PC needs to consider Local Area Networking, WLAN, Wide Area Networking, monitoring and control of switches, multiple video/camera interfaces and connection to other devices.

The Microbus M-PC2 system unit shown here is usually installed some distance from the screen. A single cable takes power, touch information and display details from/to the screen up to 10m away. The system unit can be positioned for ease of connection to other peripheral equipment, thus simplifying installation and maximising the connectivity capabilities of the PC. Remote antennae for the WLAN, GPS and 3G/GPRS features are supported to enable optimal positioning for best coverage and reception.

**Primary and Secondary screen inputs**, displaying the same or differing data, can be supported.

**Video Inputs** offer up to four full speed inputs for PAL or NTSC cameras. These may be used for ANPR/LPR, simple camera display or, one channel may be used as a DVR. DVR offers the facilities traditionally offered by VCRs, but with more easily reviewed timestamps for driver behaviour, vehicle security and accident analysis. Additionally, replay does not interfere with ongoing recording.

**GPS** offers support for Navigation applications and Geographic Information Systems (GIS).

With 4 **Serial Ports** and **USB 2.0**, the system provides connectivity for additional devices such as printers, RFID sensors and card swipes. The Microbus *MBX U-Ser* USB to Serial Hub offers even more expansion.

**Wireless Wide Area Networking** is utilised via the integrated 3G/GPRS modems, or alternatively, connection to PMR devices or TETRA radios using serial, USB or Ethernet.

**Ethernet and WLAN** offer local or local-to-vehicle Ethernet expansion for data synchronisation and cost effective bulk data uploads.

**Keyboard/Mouse** connection with up to 10 metres extension from the unit can benefit from the range of ruggedised backlit keyboards.

**Backup Battery** supports an orderly shutdown of software if power is lost.

The **Sound system** offers access to standard PC capabilities and may be linked to vehicle speakers or microphones for voice recognition and/or recording.

**Digital I/O**, via the Microbus *Relay Box*, enables monitoring, control and power management to other equipment in the vehicle. For example, control of the system start-up can be achieved via the vehicle's ignition system. Lightbars, lights and sirens may be controlled and similarly monitored.

For further details on each of these features, please refer to the specific product leaflets or contact your local supplier.